

USER AND SERVICE MANUAL

FUSION CURING LIGHT (2008 RELEASE – Rev. 2.0)



For dental use only!

⚠ U.S. Federal Law restricts this device to sale by or on the order of a licensed dentist.
Made in USA



QUICK REFERENCE

I. Operation – Press and hold POWER Key to turn on unit display (similar to cell phone). Press MENU Key to set at a common timing mode (typically 5 or 10 seconds). Press ON/OFF Key for curing and put back to Charging Stand when finished or at the end of each day (leave display on).

II. Recommended Curing Times

The high intensity profile of FUSION enables plasma-like curing speed.

1. Normal composite resin (2mm A3 or lighter): 5 seconds.
2. Orthodontic bonding resin: 3~5 seconds
3. Veneer

* Tacking: 1~2 seconds

* Bonding: 4-5 seconds

Perform curing test outside the mouth to determine curing times needed for specific resin, sealants, and bonding materials. Do not overcure to avoid overheating.

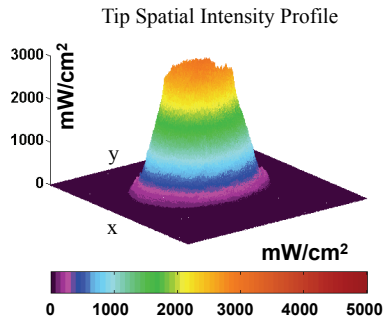

III. Heat Management

To overcome heat, use simple cooling methods such as blowing air from an air syringe in close proximity to the Light Head and tooth being restored. Use Half Power (Standard Power) Mode to avoid heat when needed.

IV. Maintenance – Light must be used with disposable barrier sleeves to avoid liquid damage and cross contaminations. **DO NOT IN ANY CIRCUMSTANCES ULTRASONIC OR AUTOCLAVE THE LIGHT.**

V. Connection - Ensure good mechanical and electrical contacts at both junctions of Light Head to Main Control and Battery Assembly to Main Control. Make sure there is no loose connection.

PARTS LIST

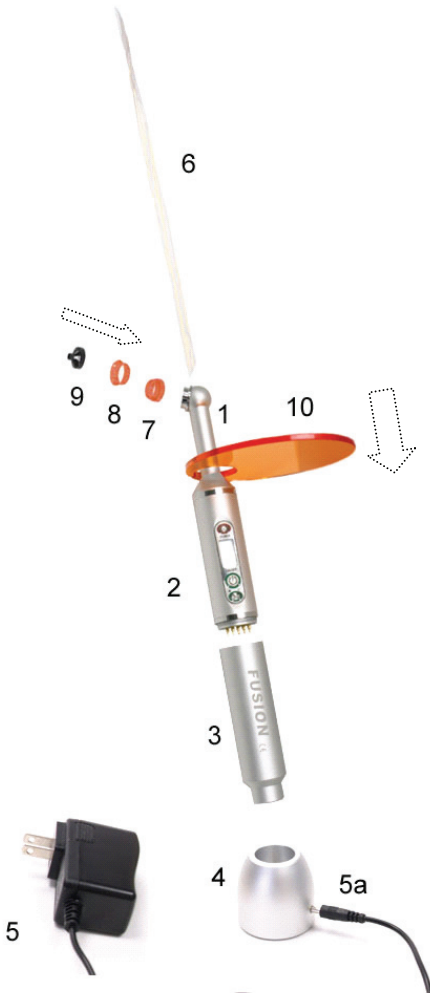

1 LED Light Head

2 Main Control Unit

3 Battery Assembly

4 Charging Stand

5 Power Adapter and Adapter Power Jack
(5a)

6 Barrier Sleeves (100)

7 9mm Curing Caps (2) *

8 13mm Curing Caps (2) *

9 3mm Tips for Tacking or Exam (2) *

10 Unit Mount Eyeshield **

* Included in standard kit

PN: 7500080-08

**Included in ortho kit

PN:7500080-08-O

1. INITIAL SET UP

1.1 CHARGE BATTERY ASSEMBLY

Before use, charge Battery Assembly overnight either direct or on Charging Stand from Adapter Power Jack. Plug Power Adapter into a wall plug or power plug.

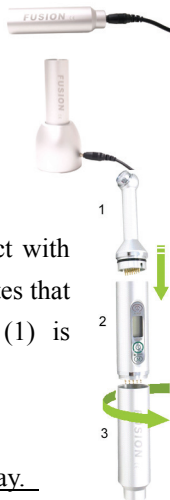

1.2 ASSEMBLE HANDPIECE

Turn Battery Assembly (3) clockwise and screw-on connect with Main Control Unit (2). A short beep upon connection indicates that the battery is ready. Ensure 360° swivel Light Head (1) is connected tight with Main Control (2).

1.3 POWER ON DISPLAY AND SELECT MODE

Press and hold POWER KEY for 5 seconds to turn on display.

Press MENU KEY to select an operation mode. Digital Timer displays operation modes (1, 2, 3, 4, 5, 10 and 20) when MENU KEY is pressed successively. Seven modes are grouped in Sequential and Constant Power modes. Constant power mode is recommended for curing single tooth. Sequential mode is recommended for full arch curing.

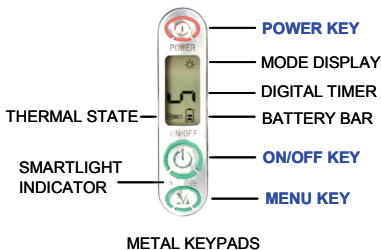

Menu Key		Constant On; Count Down; 5-second per beep		
Mode Display	☀	5	10	20
Timing Sequence		5 sec.	10 sec.	20 sec.

CONSTANT POWER MODE

Menu Key		80 seconds count down for 16 teeth in a roll; 5-second per beep			
Mode Display	⏸	1		2	
Timing Sequence		1 sec. On	4 sec. Off	2 sec. On	3 sec. Off
Mode Display	⏸	3		4	
Timing Sequence		3 sec. On	2 sec. Off	4 sec. On	1 sec. Off

SEQUENTIAL POWER MODE

2. OPERATION

2.1 ACTIVATE CURING

Make sure LCD display is on (Ref. 1.3). Grip in either pen style (a) or torch style (b). Rotate 360° swivel Light Head and point light towards curing composite. Press ON/OFF Key to activate curing. DIGITAL TIMER counts down in seconds. Press ON/OFF Key any time during the cycle to stop (cycle auto recalls in 15 seconds). An audible signal beeps at start, during (every 5 seconds) and completion of cycle. An audible beep signals key activation (Power, Menu or ON/OFF) together with visual backlight signals for MENU and ON/OFF key activation.

2.2 POWER MODE

Default power mode is plasma-like High Power Mode for quick and deep curing. Press Power Key in

any modes after activating curing to switch to Standard LED Power Mode (Half Power mode) (800mW/cm²) to minimize heat (Ref. III, 4v). Press Power Key again to switch back to High Power Mode.

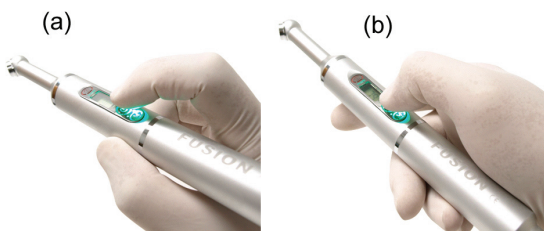

2.3 CURING TIMES

For specific resin, sealants and bonding materials, perform a timed curing test outside the mouth using a 3mm hardness disk. Cure from the top for the recommended time, and reverse the disk. Using a sharp instrument, compare the hardness of the disk to the hardness of the composite - it should feel exactly the same if well cured. For general guidance, use recommended curing times in section II and table below.

Manufacturer	3M		Ivoclar		Dentsply		Kerr	
Resin Brand	Filtek Supreme Plus		Heliomolar	Tetric EvoCeram	TPH3		XRV Herculite	
Color/Shade	A3E	C6D	A3	A2	A3	DY	A3	YB
Cure Times	5	15	5	5	5	5	5	5

Recommended Cure Times (s)

3. BATTERY MAINTENANCE

Battery Assembly uses a high capacity Lithium-Ion battery with built-in smart recharging electronics. In the office, keep unit display on and keep light charged at all times when not in use by one of the following method:

- (c): Place the handpiece in the Charging Stand;
- (d): Direct plug in the Adapter Power Jack from the Power Adapter to the receptor end of the handpiece. Switch to this corded operation in the event of low battery during operation;
- (e): Place the handpiece into a Dental Unit Charge Holder (optional accessory (f)), which can be mounted on a standard dental unit bar or cabinet bar (g) via its two bottom set screws. The Dental Unit Charge Holder connects to Power Adapter through its outlet power jack (f1) and extension cord (f2).

SMARTLIGHT

INDICATOR is green while charging and turns off when fully charged. Battery icon displays three full bars when the battery is fully charged. The unit warns with short audible beeps when battery is low then automatically shuts down with a long beep together with flashing backlight and battery bar.

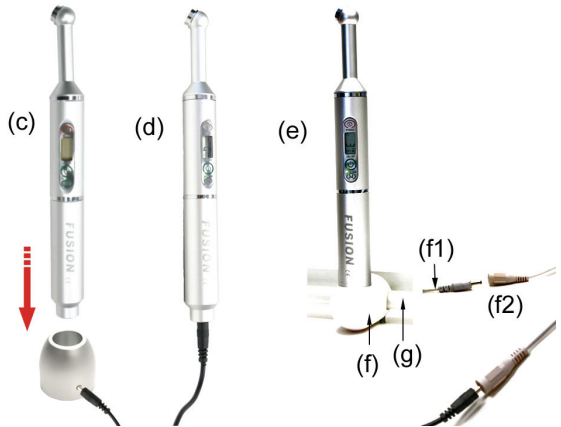

For temporary storage or transport, shut down the unit by pressing and holding Power Key for 5 seconds until display is turned off indicated with a short beep. For extended period storage, unscrew battery assembly and storage with care.

- Do not store above 40°C or below -10°C.
- Storage period must not exceed 6 months.

4. SAFETY PRECAUTIONS

- i) **LIGHT MUST BE USED WITH BARRIER SLEEVES TO AVOID CROSS CONTAMINATIONS AND LIQUID DAMAGE. REPLACE THE DISPOSABLE BARRIER SLEEVES AFTER EACH PATIENT USE.**
- ii) Do not touch and open any electronics parts and circuit boards. **Warranty void if seal broken.**
- iii) Do not drop the light. Use instrument tray, Charging Stand or Eyeshield to avoid roll over on table. **WARRANTY VOID IN CASE OF DROP DAMAGE.**
- iv) Do not immerse handpiece in waters or solutions. **WARRANTY VOID IN CASE OF LIQUID DAMAGE.**
- v) As it is the case with all high-performance lights, the high light intensity of FUSION results in a certain heat development. Prolonged exposure of areas near the pulp and soft tissues may result in irreversible or reversible damage. Therefore, this high-performance curing light must only be used by trained dental professionals:
 - Do not place light directly on the same tooth segment for more than 10 seconds in the High Power mode.
 - Do not place light in direct contact with unprotected gingival, oral mucous membrane or skin. Prevent heat accumulation with a rubber dam in place.
 - Place curing light directly over materials to be cured at all times.
 - If irradiation of soft tissue or sensitive patients cannot be avoided, operate in Half Power Mode, adjust curing distances and blow air from an air syringe in close proximity to the Light Head.
- vi) **DO NOT LOOK DIRECTLY AT LIGHT EMITTED FROM THIS CURING UNIT.** Use suitable eye protection for the operator and assistants: curing caps (partial light shield at the tip of the curing light), unit mount Eyeshield, and Goggles (reference section 10).
- vii) Charge batteries while not in use to extend the lifetime of the rechargeable battery.
 - **Do not short circuit battery.**
 - Do not use power adapters from sources other than the manufacturer.
 - Dispose of unserviceable batteries and curing lights according to the national rules and regulations. Batteries must not be incinerated.
 - Replace the battery assembly after the lifetime of the battery usage by ordering replacement Battery Assembly (Ref. 10).

5. CLEANING AND DISINFECTING

- Thoroughly wipe off handpiece and Charging Base with a soft cloth or tissue dampened with cleaning solution, isopropyl alcohol or soap and water. Do not spray or soak. Disinfecting agents and water must not enter any openings on unit in particular METAL KEYPAD.
- Clean curing lens and electrical metal contacts using Q-tips slightly dampened (do not soak) with isopropyl alcohol.
- Safeguard handpiece opening area, metal keypad, charging plug, and lens against liquid and sharp objects as this may cause electrical short-circuit, permanent optical damage or malfunction.**

6. TECHNIQUES AND ADJUNCT TOOLS

6.1 BARRIER SLEEVES

Slide sleeve into handpiece. Twist body relative to sleeve for tight fit.

6.2 OPTIONAL EYESHIELD

Slide eyeshield through the Light Head into handpiece body. Adjust sliding position for easier access.



6.3 LENSES

Use disposable barrier sleeves and curing caps to protect lenses from liquid and composite damages. Replace lens module immediately if it:

- has cured resin;
- is cracked, scratched or cloudy.

Align and lock flat edge of Lens Tool (Ref. 10) to flat edge of Lens Module. Turn Lens Tool counter-clockwise and unscrew Lens Module. Clean mounting thread. Replace damaged lens with a new Lens Module by reversing the above steps.

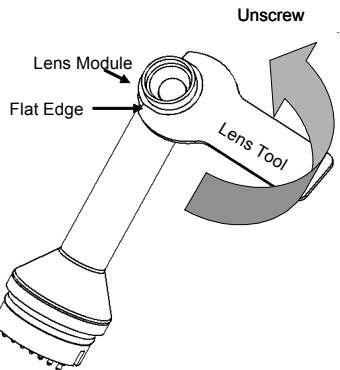

6.4 TIP SIZE

Tip and beam size from the curing light can be adjusted using a combination of 3mm (tacking and exam tip), 9mm or 13 mm caps in combination with Focus or Expanded Beam Lens Module (optional, Ref. 10). For example:

- 3mm tip: snap on 3mm caps to the Focus Lens Module;



- 13mm tip: use Expanded Beam Lens Module (optional accessory) and snap on orange 13mm curing caps



6.5 ADJUNCT TOOLS

Three optional light heads are offered for composite curing or oral exam.

Standard Light Head comes with the kit for LED light curing applications with photoinitiators active to wavelengths from 420-490nm.



Violet Light Head option cures composites with violet wavelength photoinitiators.



White Light Head offers an exam probe light that provides intra oral illumination and detection of dental caries, cracks and oral diseases.

6.6 ERGONOMICS-DENTAL UNIT CHARGE HOLDER

This option provides the user a convenient mounting and charging option on a standard dental unit or cabinet unit with half-inch bar to save counter space, provide easier access and roll-over protection (Ref. 3e).



7. TECHNICAL SPECIFICATIONS

Voltage	100-240 V (50/60Hz) to Power Adapter; Regulated 5V DC to handpiece.
Lamp	High Power LEDs. 100000 hours lifetime.
Wavelength	Standard Light Head: 420 – 490 nm
Range	White Light Head: 5000-6500 K
Light Intensity	Standard Light Head: 1500 mW/cm ² (±10%) (High Power Mode); 800 mW/cm ² (±10%) (Half Power/Standard Power mode) Violet Light Head: 500 mW/cm ²
Battery	Lithium Ion. 90 minutes recharge time. 35-45 minutes continuous run time. 500 full charge-discharge life cycles.
Shutoff	Timer auto shutoff; User shut off anytime by pressing On/Off key; Low battery auto shutoff; Overheat auto shutoff (typically after 4 minutes continuous run time in full power). Self protection shutoff is accompanied by warning backlight and audible alarm as well as flashing

THERMAL STATE or BATTERY BAR symbols.

Operating Temperature	0 –35 °C
Storage	Take apart Battery Assembly from Main Control Unit; Storage temperature: -10 – 40 °C
Weight	111 grams
Dimension	22 mm diameter; 200 mm full handpiece length.
Standards	Complies to CE 89/336/EEC, EN60601-1-2, EN61000-3-2, EN61000-3-3, IEC60601-1-2

8. LIMITED TWO-YEAR WARRANTY

Register your purchase of **FUSION** at www.dentlight.com. DentLight Inc., the manufacturer, extends a two-year warranty against defects in material and workmanship to the original purchaser of this product from an Authorized dealer, except the Battery Assembly and Charging Stand (one-year warranty). This warranty is valid providing factory inspection indicates that any such defect developed during normal and proper use. DentLight shall under no circumstances be liable for incidental, special, consequential damages or damage from misuse including the following expressed or implied:

- Improper operation, accident or neglect, misuse or abuse, such as physical damage (drop, dents, cracks, scratches, etc.);
- Liquid, water, rain, extreme humidity, ultrasonic, autoclaving;
- Improper repairs or modifications that have not been carried out by a certified Service Center;
- Use of other spare parts and accessories than from the manufacturer such as power adapter;
- Other acts which are not the faults of DentLight.

In case of a claim under warranty, the complete apparatus must be returned, carriage paid, to your dealer or directly to DentLight. Please fill out return form (http://www.dentlight.com/files/Request_Return_Authorization.pdf) together with an approved RMA number and proof of purchase.

9. TROUBLESHOOTING GUIDE

TROUBLE	CAUSES	ERROR INDICATION	CORRECTIVE ACTION
Handpiece			
Light cannot be activated	Unit Power is not turned on.	LCD display is blank.	Press and Hold Unit Power Key until the LCD display turns on. Then select a mode and press On/Off Key (Ref. 1.3).
Light cannot be activated	Battery icon shows one bar or no bar.	LCD Battery Indicator is low or LCD is blank and can not be turned on with Unit Power Key.	Charge the battery. If LCD is blank, charge the battery assembly separately overnight by first unscrewing the battery from the main control unit and then plug in the power adapter directly (Ref. 1.1).
Light cannot be activated	Handpiece is overheated.	The handpiece, in particular the Light Head is hot.	Allow the handpiece to cool down in ambient or with convection air from suction tip or compressed air (Ref. III, 7).
Light cannot be activated or shuts down prematurely	Bad electrical contacts and connection between the Battery Assembly and Main Control Unit. Damaged connection pin.	Shuts down even when battery is full. Shows digital timer count down and hears beeps. Light works inconsistently.	Clean metal contacts (Ref. 5b). Ensure good and tight connections (V). In case of damaged electrical pins, contact the manufacturer for service.
Battery Assembly			
Battery not holding charge	Electronic defect in the Battery Assembly. Drop damaged Battery Assembly.	Operating inconsistently. Shuts down even when battery icon shows full bar and battery screwed in tight. Battery Assembly end with drop mark and loose component inside.	Please contact manufacturer or your dealer for service or replacement of Battery Assembly.
Battery not being charged	Electronic defect in the Charging Stand.	Battery icon shows one or two bars; Charge Indicator shows no light while charging; Charge Indicator turns green while bypassing Charging Stand and directly plugging into the handpiece.	Please contact manufacturer or your dealer for replacement of Charging Stand.
Battery not being charged	Electronic defect in the Battery Assembly.	Battery icon shows one or two bars. Charge Indicator shows no light while charging from Charging Stand or directly plugging into the handpiece.	Please contact manufacturer or your dealer for service or replacement of Battery Assembly.
Main Control Unit			
Keypad malfunctions. Unable to turn on LCD screen, set timer, or turn on light	Electronic defect from liquid damage, short circuits and drop damage.	After charging Battery Assembly, LCD screen still does not turn on with POWER KEY, or can not set timer with MENU KEY, or can not activate curing light with ON/OFF key (Ref. 1.3).	Contact the manufacturer or your local dealer for service or replacement of Keypads or Main Control.

10. REORDER AND OPTIONAL ITEM CODES

PN	Description
7500080-08	FUSION Curing Light Kit - Silver
7500080-08-P	FUSION Curing Light Kit - Pink
7500080-08-B	FUSION Curing Light Kit – Blue
7500080-08-G	FUSION Curing Light Kit - Gold
7500081	Curing Caps – 9mm (50/pack)
7500081B	Curing Caps – 13mm (50/pack)
7500081C	Tacking Tips – 3mm (20/pack)
7500082	Barrier Sleeves (100/pack)
7500083	Charging Stand
7500084-08	FUSION'08 Battery Assembly
7500085	Power Adapter
7500088	Eye Goggle
7500092	Unit Mount Eye Shield
7500093	Focus Lens Module
7500094	Expanded Beam Lens
7500095	Lens Tool
7500050	Main Control Module
7500060	Standard Light Head Module with Focus Lens
7500060W	White Light Head Module with Focus Lens
7500060U	Violet Light Head Module with Expanded Beam Lens
7500071	Dental Unit Charge Holder
7500072	Chair Power Extension Cord
7500070	FUSION'08 CHAIR SYSTEM



DentLight Inc.

1411 E. Campbell Rd # 500
 Richardson, TX 75081 USA
 Tel: (800) 763 6901
 Outside US: 1-972-889-8857
www.dentlight.com



Molenstraat 15
 2513 BH The Hague
 Netherlands
 Tel: +31(0)70 345 8570
 Fax: +31(0)70 346 7299